

Attachments / **Railway**

Rail Clamshell Bucket C18VE



Efficient bucket for excavating between sleepers

Rail Clamshell Bucket C18VE is adapted for excavating between sleepers and offers an economical and flexible solution. The shells can be replaced to easily switch between functions. The bucket carrier, hydraulics and bearings are integrated into the main module.

To withstand the forces generated by the rigid mounting, the main frame of this C18VE model is specially reinforced.

The 280 mm (11 in) wide shells feature additional reinforced side walls made from 15 mm (0.6 in) Hardox steel.

 Do you have any questions? Contact us!

 **High safety**

Safe handling with non-return valve

 **Flexible**

Replaceable shells and accessories

 **Robust and durable**

Reinforced main frame

 **Long service life**

500 HB steel in the cutting edges

More information

A non-return valve ensures continuous load safety, even in the event of hydraulic pressure loss. The bucket is suitable for excavators with an operating weight between 13 and 18 tons.

Advantages

- Safe handling with non-return valve
- Flexible with replaceable shells and accessories
- Robust and durable construction
- Long service life ensured through 500 HB steel in the cutting edges and a generously dimensioned bearing system with special coating
- Excellent digging performance thanks to high closing forces
- Low overall height makes it ideal for railway applications

Features

- Robust and sustainable design for long life cycle
- Hydraulics integrated into the main frame
- Adapted for excavators 13–18 tons

Detailed description

- Weight: 315 kg (excluding bracket and accessories)
- Height: 1280 mm (including accessories)
- Max load: 4500 kg

Excavator requirements

- Recommended operating weight: 13–18 ton
- Operating pressure: maximum 320 bar
- Pump capacity: 75–150 l/min

Accessories

- Bolt-on Bracket AGS
- Fully automatic quick coupler systems from all manufacturers
- Shells with width 280 to 1000 mm, Sleeper Grapple, Rail grapple
- Rotator for excavator
- Rotator for crane mounting

Product	Item number	Description	Standard bucket width (mm)	Opening (mm)	Load capacity (kg)	Volume (l)	Number of teeth	Weight (kg)
C18VE/Rig-Rail	255-18030-320-28	Hydraulic base unit	280	1350	4500	100	3	490

Product description and accessories

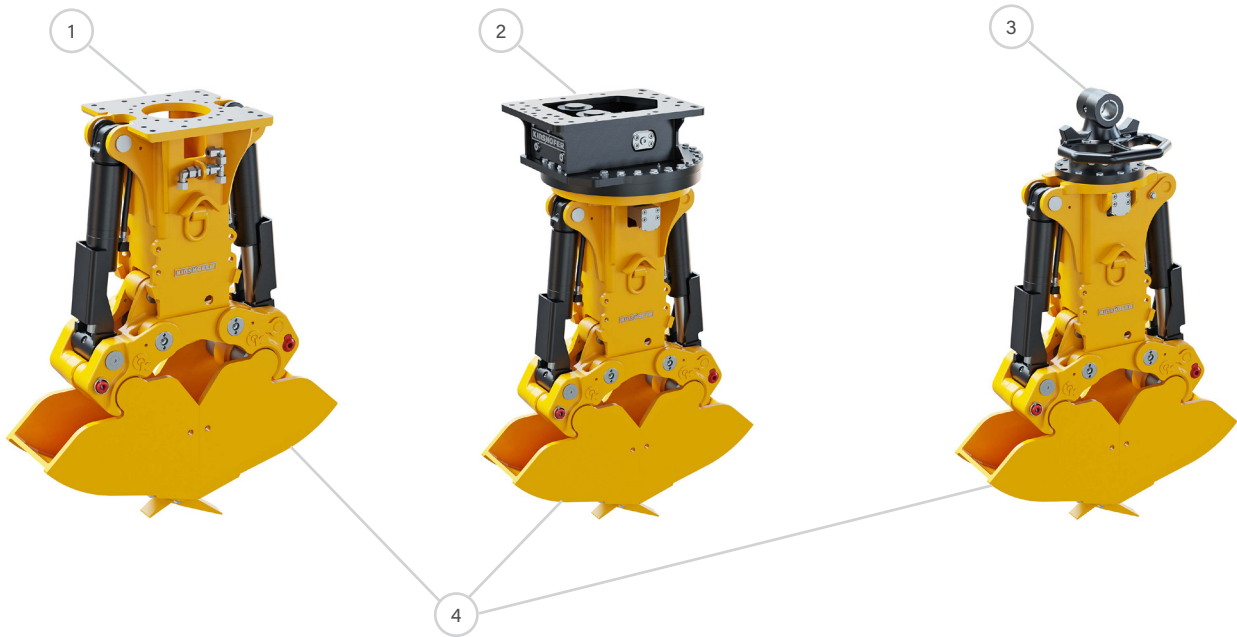

1. For bolt-on bracket

2. Rotator for bolt-on bracket

3. Rotator for crane

2. Exchangeable shells / tines

Technical specification

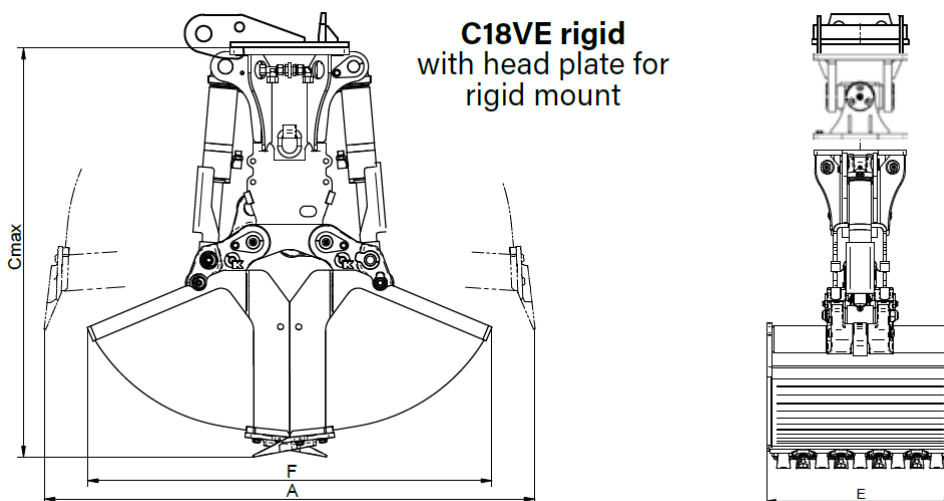





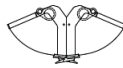

Standard bucket Width B (mm)	Opening A (mm)	Height C max (mm)	Length F (mm)	Standard bucket Volume (l)
280	1330	1280	1020	60

Exchangeable shells for C18VE

Exchangeable shells for C18VE - rigid and cardanic mount



Shells are interchangeable and available in all widths. Fast exchange thanks to shell exchange aid kit

Product	Width (mm/in)	Opening (incl. teeth) (mm/in)	Total height (mm/in)	Volume (liters/c.y.)	Number of teeth	Load capacity (kg/lbs)	Closing forces (kN/lbf)	Weight (shells only) (kg/lbs)
Excavating Shells			C18VE-40S	C18VE-28S				
C18VE-28S-Rail	280 / 11.0	1330 / 52.4	1500 / 59	60 / 0.08	3	4500 / 9900	54 / 11880	150 / 330
C18VE-40S-Rail	400 / 15.7	1330 / 52.4	1500 / 59	100 / 0.13	3	4500 / 9900	54 / 11880	170 / 374
C18VE-50S-Rail	500 / 19.7	1330 / 52.4	1500 / 59	125 / 0.16	5	4500 / 9900	54 / 11880	185 / 407
C18VE-60S-Rail	600 / 23.6	1330 / 52.4	1500 / 59	150 / 0.19	5	4500 / 9900	54 / 11880	215 / 473
C18VE-80S-Rail	800 / 31.5	1330 / 52.4	1500 / 59	200 / 0.26	7	4500 / 9900	54 / 11880	265 / 583
C18VE-100S-Rail	1000 / 39.4	1330 / 52.4	1500 / 59	250 / 0.33	9	4500 / 9900	54 / 11880	315 / 693

Sleeper Grab Tines								
C18VE-50S RG	500 / 19.7	1250 / 49.2	1400 / 55.1	-	-	4500 / 9900	44 / 9680	130 / 286
Multi Purpose Tines								
C18VE-60S A	590 / 23.2	1660 / 65.4	1625 / 64.0	180 / 0.24	5	4500 / 9900	41 / 9020	340 / 748
Well Shaft Shells								
C18VE-97S WSG	Ø970 / 38.2	970 / 38.2	1410 / 55.5	110 / 0.14	5	4500 / 9900	65 / 14300	170 / 374

Note: larger shells available on request

Exchangeable shells for C18VE - only cardanic mount

Product	Width (mm/in)	Opening (inkl. tänder) (mm/in)	Total height (mm/in)	Volume (liters/c.y.)	Number of teeth	Load capacity (kg/lbs)	Closing forces (kN/lbf)	Weight (shells only) (kg/lbs)
Rail Grab Tines								
C18VE-200S-RG2	2000 / 78.7	990 / 39	1295 / 51	-	-	4500 / 9900	68 / 14960	275 / 605
Hay and Forestry Tines								
A18VE-95S	955 / 37.6	1830 / 72	1685 / 66.3	400 / 0.52	-	4500 / 9900	41 / 9020	340 / 748
A18VE-122S	1220 / 48	1835 / 72.2	1725 / 67.9	600 / 0.78	-	4500 / 9900	32 / 7040	275 / 605
Timber Grab Tines								
T18VE-49S-0,5	490 / 19.3	1830 / 72	1825 / 71.9	0,50 m ² / 0.33 cords		4500 / 9900	30 / 6600	200 / 440
T18VE-49S-0,6	490 / 19.3	1975 / 77.8	1905 / 75	0,60 m ² / 0.40 cords		4500 / 9900	33 / 7260	220 / 484

Package consists of: Exchangeable shells, teeth (excavating and well shaft shells), exchange aid kit

Note: special shells available on request