

Attachments / **Railway**

Cable Trench Lid Grapple GRL Premium



Premium grapple with wide grip width and high safety

Cable Trench Lid Grapple Premium GRL is a flexible and efficient tool for quick and safe handling of new or old pallet-stacked cable trench lids. The grapple is specially developed for handling and positioning lids in existing cable trenches. The grapple tines are parallel and equipped with a load-holding valve that provides a safe grip even if hydraulic pressure drops. Rubber grips on the tines provide a secure hold without damaging the lids. It is built for trench lids 380–1380 mm long and has adjustable grip width 270–1270 mm. Grapple width is 350 mm.

 Do you have any questions? Contact us!

 **Safe handling**

Quick and safe handling of cable trench lids

 **Adjustable**

Adjustable parallel tines with load-holding valve

 **Gentle**

Gentle grip with rubber grips

More information

Features

- Built for trench lids 380–1380 mm long
- Adjustable grip width: 270–1270 mm
- Load-holding valve and parallel tines

Detailed description

- Weight: 235 kg
- Max load: 800 kg
- Internal grip height: 1080 mm
- Grapple tine width: 350 mm

Machine requirements

- Recommended machine weight: 8–24 ton
- One double acting hydraulic circuit
- Max pressure: 250 bar
- Oil flow: 40–60 l/min

Accessories

Bolt-on Bracket AGS, Fully automatic quick coupler systems from all manufacturers

| Product | Item number | Load capacity (kg) | Width grapple tines (mm) | For trench lid (mm) | Weight (kg) |
|---------|------------------|--------------------|--------------------------|---------------------|-------------|
| GRL | 315-02000-000-80 | 800 | 350 | 380 - 1380 | 700 |

Product description and accessories

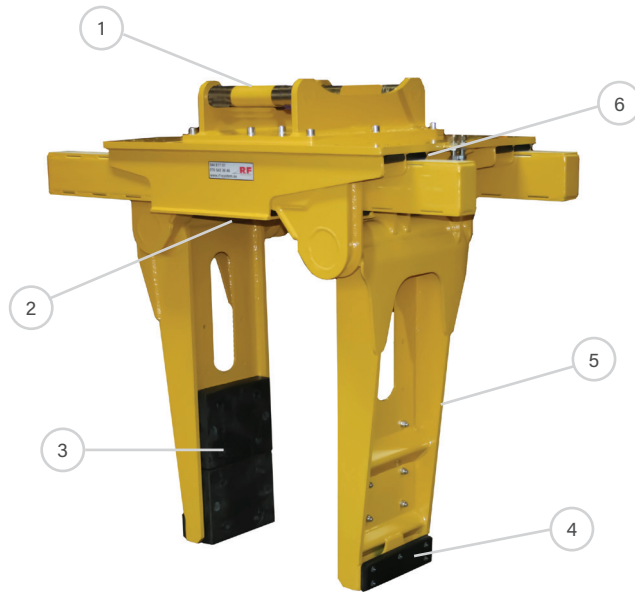

1. Bolt-on bracket

2. Rubber protection

3. Rubber coated grapple arms

4. Outer rubber protection

5. Grapple arm

6. Hydraulic cylinder

Technical specification

