

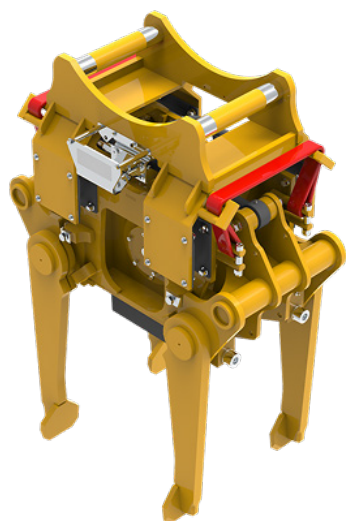

See product video



Attachments / **Railway**

# Ballast Tamper RST

## Efficient ballast tamper with high frequency

The Ballast Tamper RST is a well-proven machine with a low profile that fits all excavators and cranes. Weighing only 680 kg and with a replaceable attachment, it can be used on several different machines, ranging from 12-24 tons.

The tamper packs ballast efficiently with high frequency (60 Hz) and minimal noise levels. The tamper legs have durable and proven bearings, developed in collaboration with leading ball bearing suppliers, to ensure long service life. As standard, the tamper comes with an adjustment plate of 110 mm for a 400 mm packing depth.

 Do you have any questions? Contact us!

 **High Compaction Force**  
7 500 kg

 **High Frequency**  
60 Hz with minimal noise levels

 **Low Weight**  
680 kg

## More information

The latest generation features reinforced legs and a newly developed hydraulic system with a pressure-compensated valve for the hydraulic motor, as well as pressure relief for safe operation of the tamper legs. The motor, which can withstand higher back pressure, is included as standard, with an optional motor with drain available.

For easy relocation, the tamper can be fitted with a bolted handling bracket, compatible with the tiltrotator's grip.

### Features

- Replaceable attachment for flexibility between machines
- Reinforced tamper legs and new hydraulics with pressure-compensated valve
- Motor withstands higher back pressure, optional drainage motor
- Adjustment plate 110 mm for 400 mm packing depth
- Optimal compaction occurs 70-100 mm below the ties
- Production: Approx. 150-200 packings/h (full tie change), approx. 250-300 packings/h (light compaction)

### Detailed Description

- Weight: 680 kg
- Motor: 14,6 cc

### Machine Requirements

- Recommended machine weight: 12-24 tons
- Option 1: One double-acting and one single-acting hydraulic circuit with free return to tank
- Option 2: Two double-acting hydraulic circuits with leak oil
- Pressure: Max 350 bar
- Recommended oil flow: 50 l/min
- Oil flow: Min 50 l/min, max 170 l/min

### Accessories

Bolted handling bracket (can be retrofitted), Adjustment plate 55 mm for a 455 mm packing depth, Ground vibrator plate, Adapter boom for parallel mounting, Transport support, Fully automatic quick coupler systems from all manufacturers

Product	Operating weight	Item number	Bracket	Weight (kg)	Compaction force (kg)	Packing depth (mm)
RST 03	12 - 24	160-75107-535-18	S45	680	7500	400
RST 03	12 - 24	160-75109-535-18	S50	680	7500	400
RST 03	12 - 24	160-75111-535-18	S60	680	7500	400
RST 03	12 - 24	160-75126-535-18	Hole pattern	680	7500	400
RST-T		160-13000-000-00	Handling bracket, bolted to one pair of legs			
	Adjustment plate 55 mm	9-160-002	For packing depth 455 mm			455

## Product description and accessories

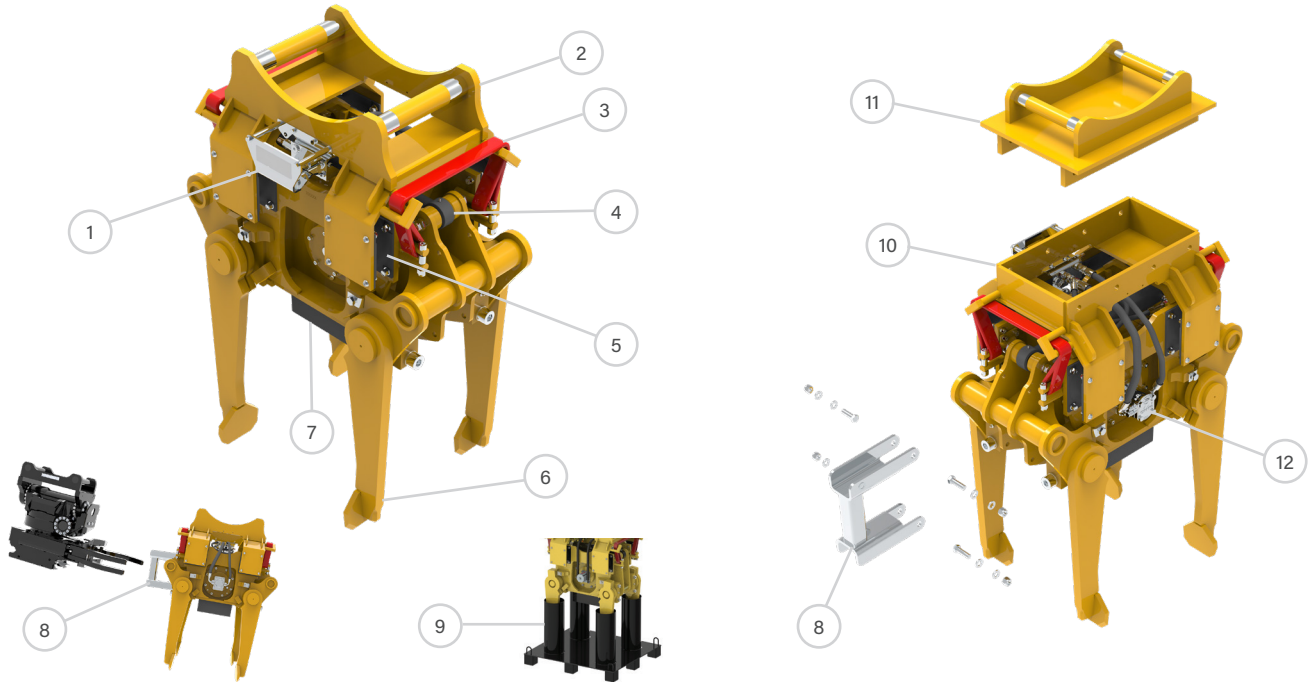

1. Protection plate hydraulic connections

2. Upper part with integrated machine coupler

3. Bar strap

4. Hydraulic cylinder for legs

5. Spring rubber

6. Legs for compacting

7. Adjustment plate for other packing depth

8. Handling bracket

9. Transport support

10. Upper part hole pattern RA

11. Adapter RA

12. Motor for vibro function

## Technical specification

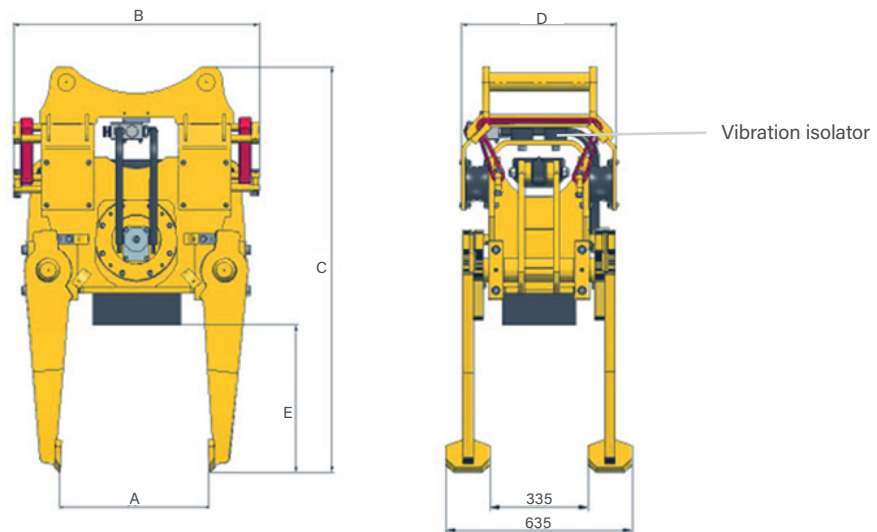

Grip area A (mm)	Length B (mm)	Height C (mm)	Width D (mm)	Depth E (mm)
195-650	830	1 310	525	505-560